



* Image for illustration purpose only



The WR Series wall mounted cabinets are built to the highest standards with flexibility and ease of installation at the forefront of design criteria. More than 30 different size and door variants makes the WR Series one of the most comprehensive in the market.

The fully welded frame ensures a stable structure while the key lockable quick release door opens to 180 degrees and are available in Acrylic, Curved Perforated or Steel.

CABINET DIMENSION:	1170H x 600W x 700D (incl. rear hinge)
REAR HINGE SECTION:	1170H x 600W x 100D
COLOUR:	Black
WEIGHT:	46kg
SHIPPING DIMENSION:	1210H x 640W x 740D
SHIPPING WEIGHT:	49kg

DESCRIPTION:	WRH Cabinet – 24RU 600W 700D Steel Door
---------------------	--

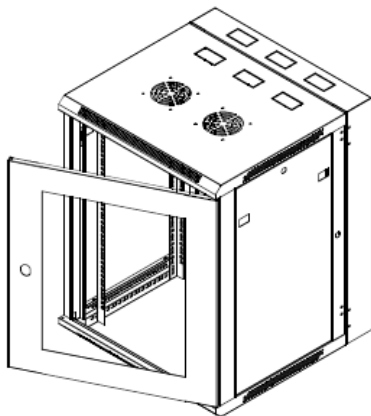

FEATURES

- Fully welded frame ensures stable structure
- Quick release door hinges
- Reversible Doors open to 180 degrees with quick release hinge
- Steel front door
- Doors flush with frame, Curved Perforated door protrudes 50mm
- 70% Perforation on perforated doors
- 19" depth adjustable mounting rail
- Side panels fitted with round locks are easy to fit and remove
- Top and bottom panel with multiple cable entry knockouts
- Rear panel with multiple cable entry knockouts
- Rear hinge section left or right side
- Rear hinge section key lockable
- Rear hinge section has 19" provisions

STANDARD INCLUSIONS

- 1 x Cantilever Shelf (1RU 300 depth cantilever)
- Key lock on front door
- Key locks on removable side panels
- Cable entry knockouts top, bottom and rear
- Fan vents in top
- Front & rear 19" mounting rails with RU marking
- Earthstud
- 25 cage nuts and screw
- Rear panel section supplied with hinges

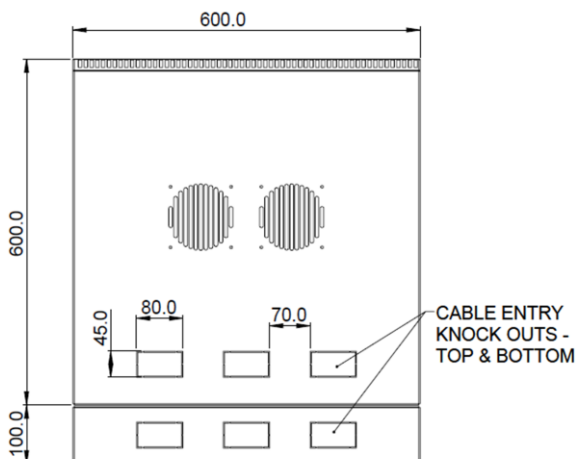

TOP VIEW - 600 DEEP WR CABINET WITH REAR HINGE BOX SECTION